



Unidad de investigación

Tarjetas de imágenes

Grado 5

Más allá de Juneteenth: de 1865 al presente

Español

© 2022 Amplify Education, Inc. and its licensors
www.amplify.com

All Rights Reserved.

Core Knowledge Language Arts and CKLA are trademarks of the Core Knowledge Foundation.

Trademarks and trade names are shown in this book strictly for illustrative and educational purposes and are the property of the respective owners. References herein should not be regarded as affecting the validity of said trademarks and trade names.

Printed in the USA
01 LSCOW 2021

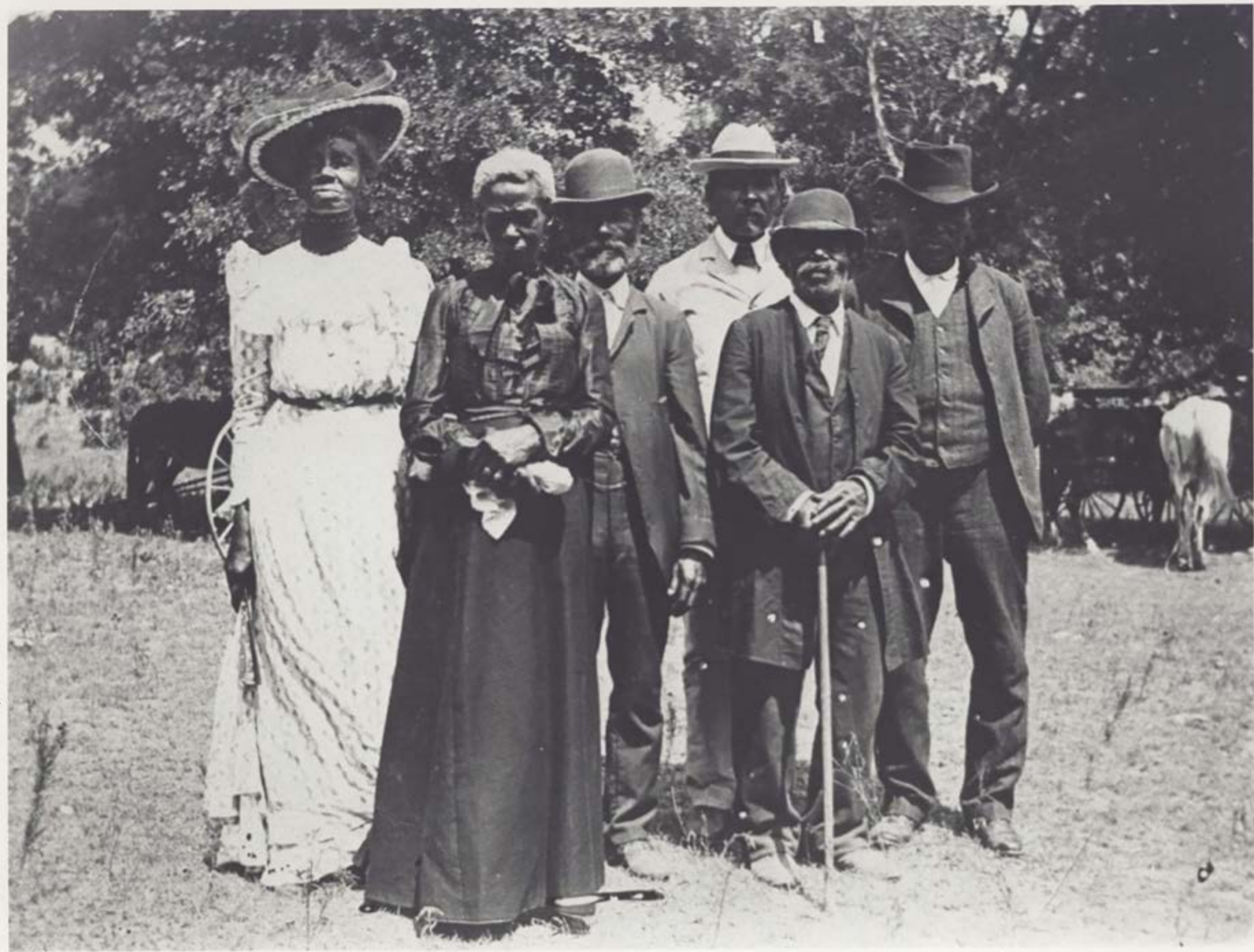



Más allá de Juneteenth: de 1865 al presente 1A-1



Más allá de Juneteenth: de 1865 al presente 1A-2





Más allá de Juneteenth: de 1865 al presente 1A-3





Más allá de Juneteenth: de 1865 al presente 1A-4





Más allá de Juneteenth: de 1865 al presente 1A-5





Más allá de Juneteenth: de 1865 al presente 1A-6





Más allá de Juneteenth: de 1865 al presente 1A-7





Más allá de Juneteenth: de 1865 al presente 1A-8





Más allá de Juneteenth: de 1865 al presente 1A-9

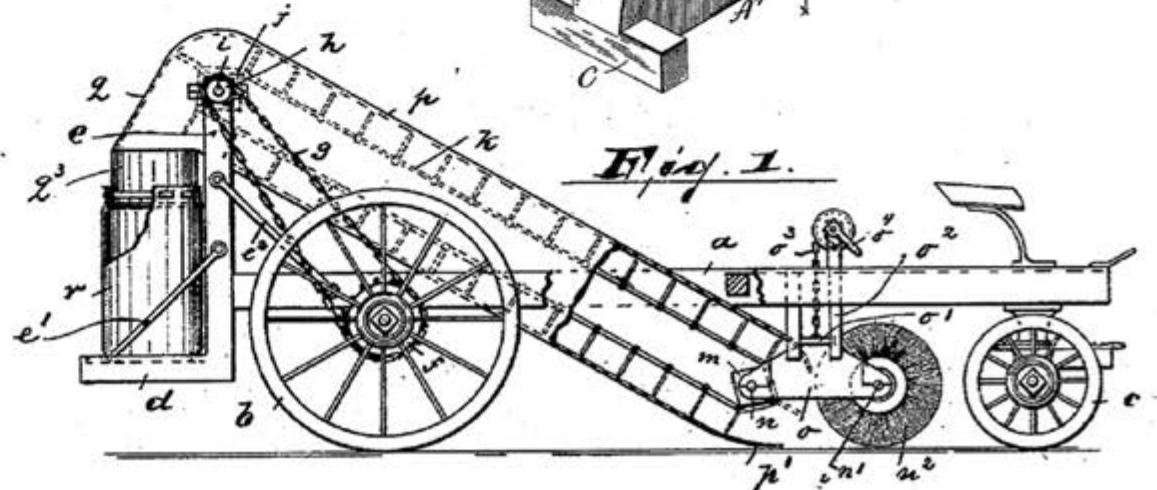
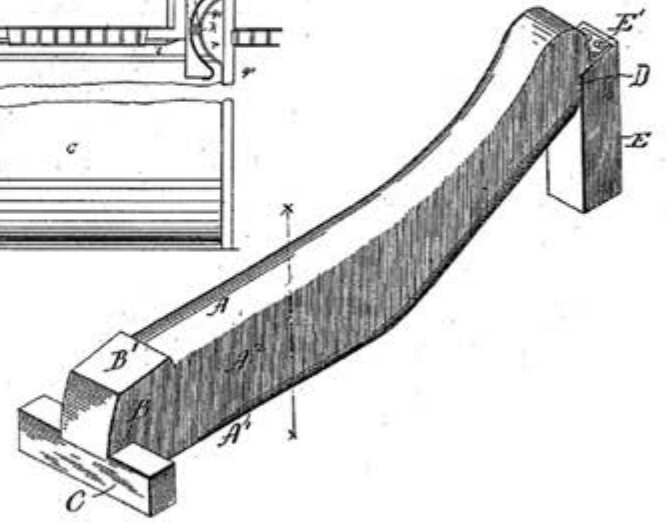
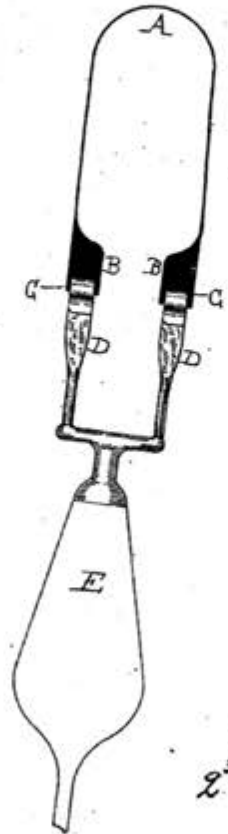
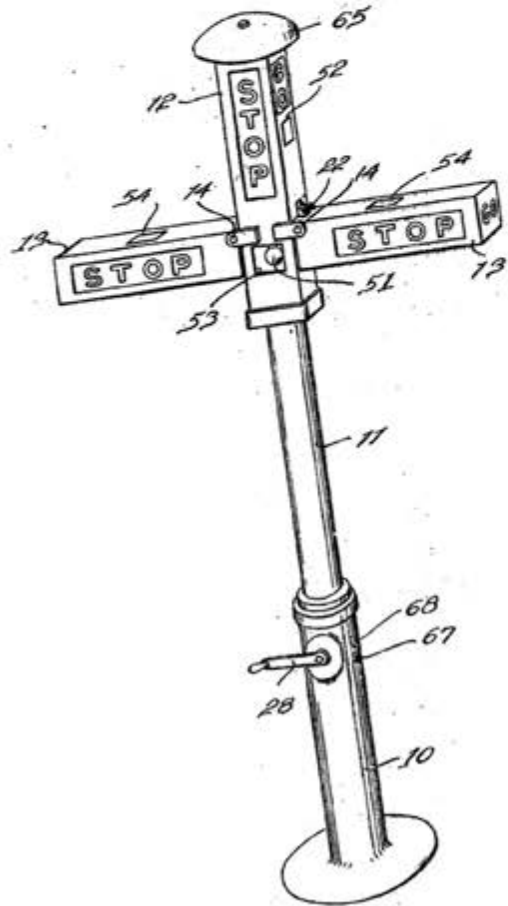
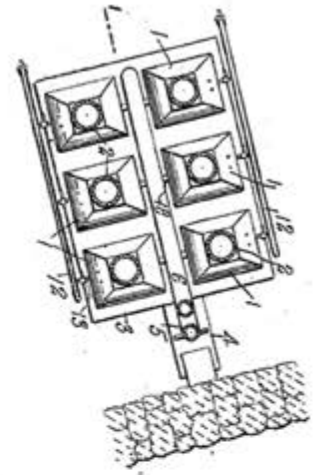
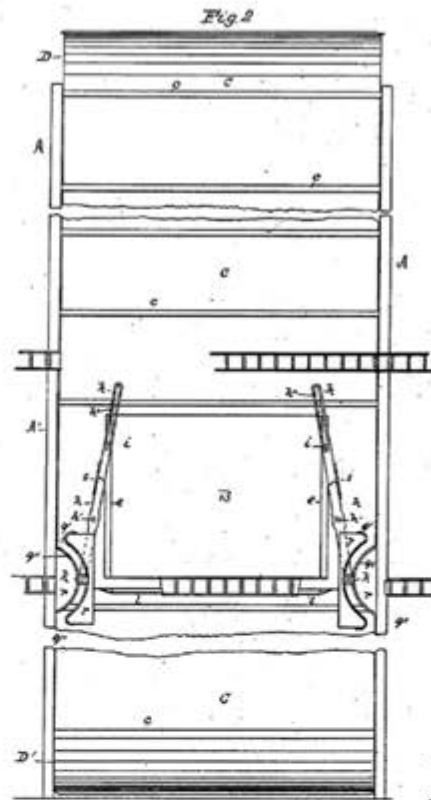
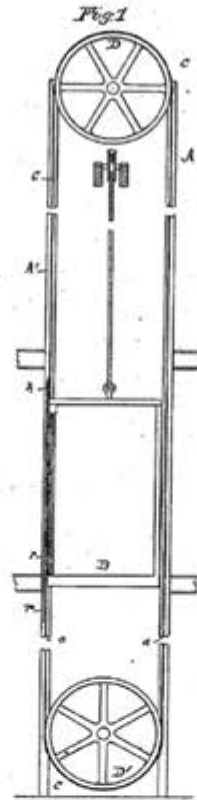
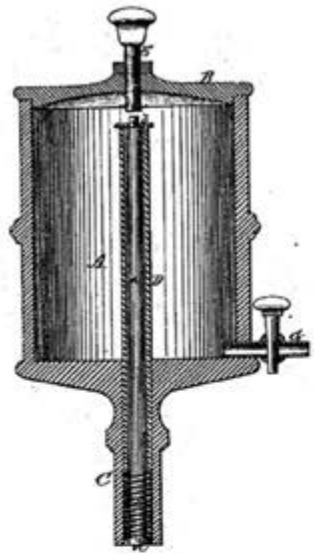



Más allá de Juneteenth: de 1865 al presente 5A-1





Más allá de Juneteenth: de 1865 al presente 5A-2



E. McCOY.

Improvement in Lubricators for Steam-Engines.

No. 129,843.

Patented July 23, 1872.

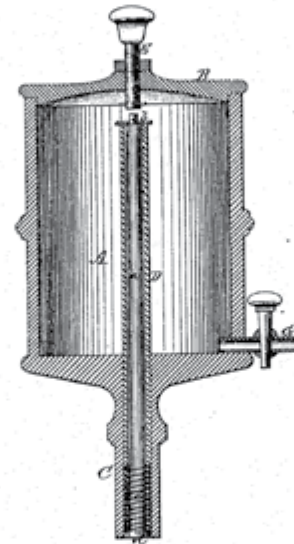

Witnesses
John A. Edlin
C. H. Watson

Inventor
Elijah McCoy
Per
W. Alexander
Atty



Más allá de Juneteenth: de 1865 al presente 5A-3



Más allá de Juneteenth: de 1865 al presente 5A-4

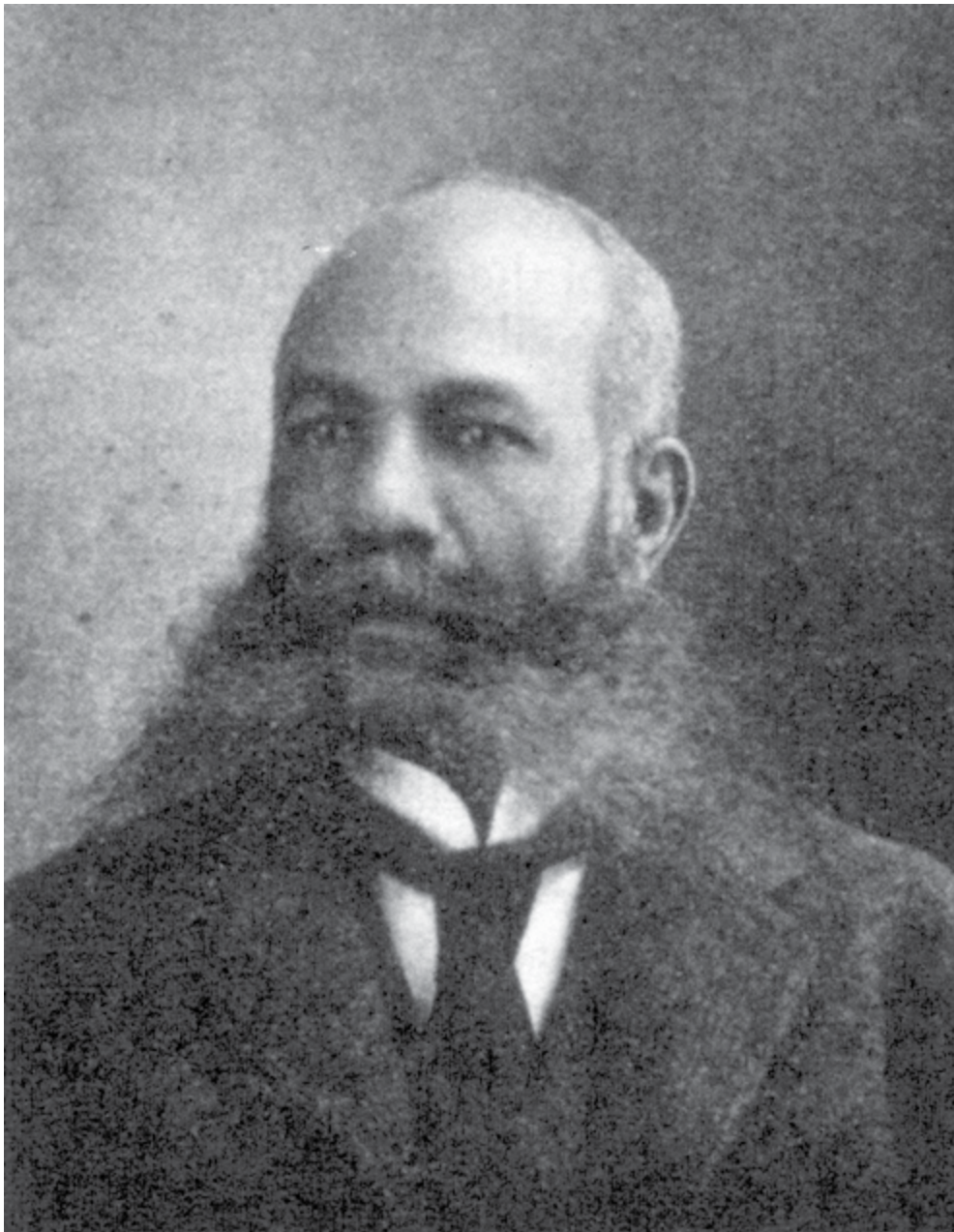

(No Model.)

3 Sheets—Sheet 1.

A. MILES.
ELEVATOR.

No. 371,207.

Patented Oct. 11, 1887.

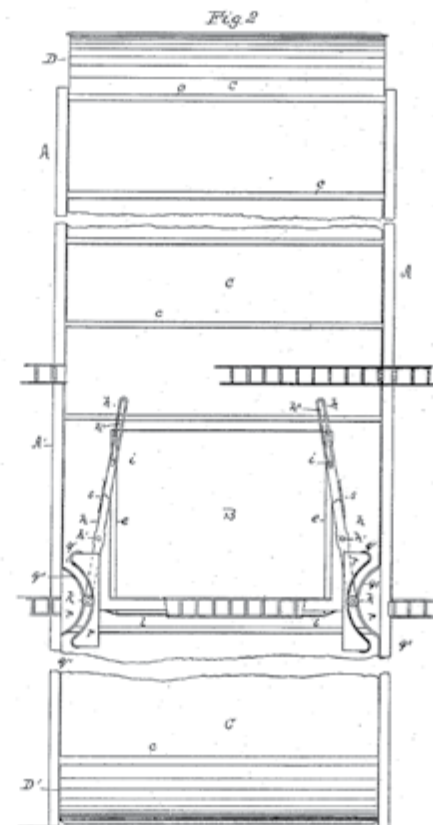
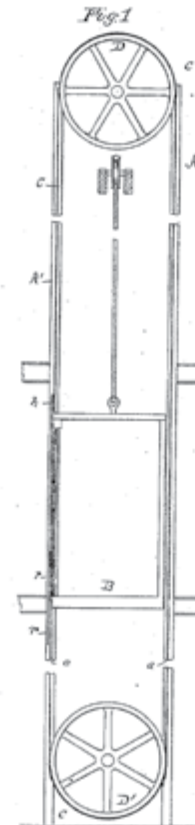

Witnesses

J. B. Paul
J. J. Jamis

Inventor

Alexander Miles

By his Attorney

P. H. Gunchel



Más allá de Juneteenth: de 1865 al presente 5A-5

(Model.)

S. BOONE.
IRONING BOARD.

No. 473,653.

Patented Apr. 26, 1892.

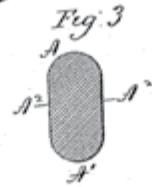
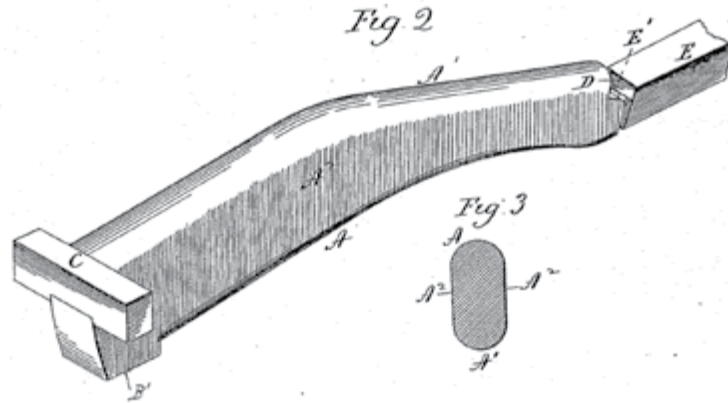
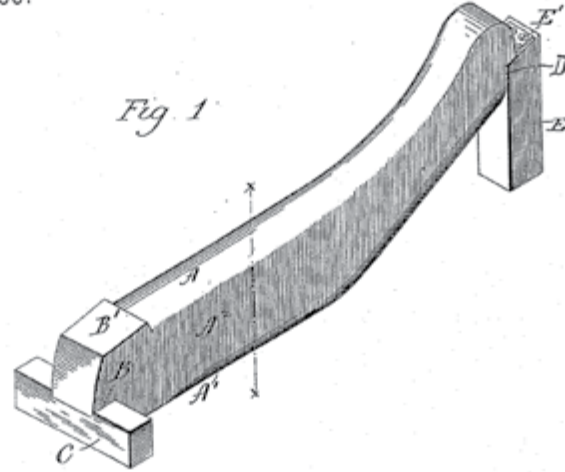

Witnesses
J. H. Shumway
William D. Kellogg

Sarah Boone
Inventor
By *Carle Seymour*



Más allá de Juneteenth: de 1865 al presente 5A-6

C. B. BROOKS.
STREET SWEEPER.

No. 556,711.

Patented Mar. 17, 1896.

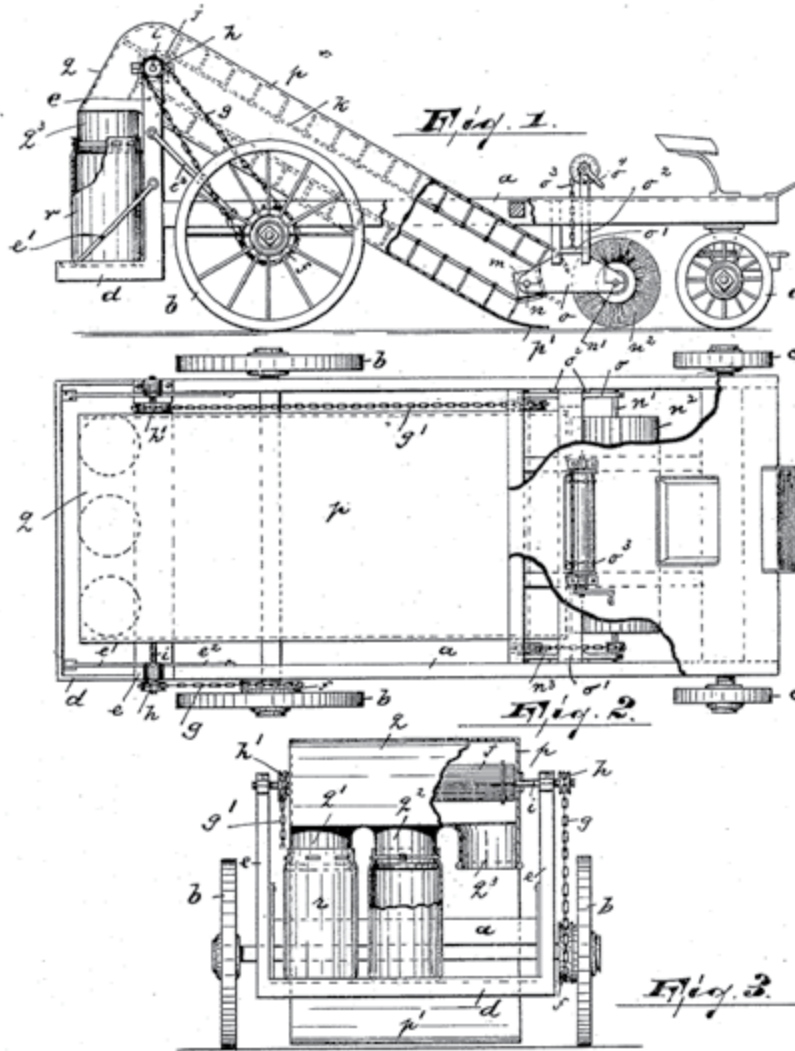

WITNESSES:
Arthur W. Thomson
Runcorn W. Robertson

INVENTOR:
Charles B. Brooks
 BY *Partners & Co*
 ATTORNEYS.



Más allá de Juneteenth: de 1865 al presente 5A-7

Nov. 27, 1928.

M. S. JOYNER
PERMANENT RAYING MACHINE
Filed May 10, 1928

1,693,515

3 Sheets-Sheet 1

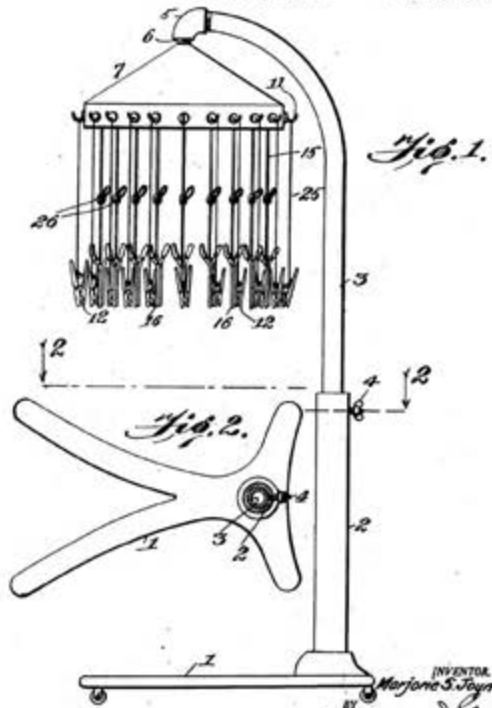
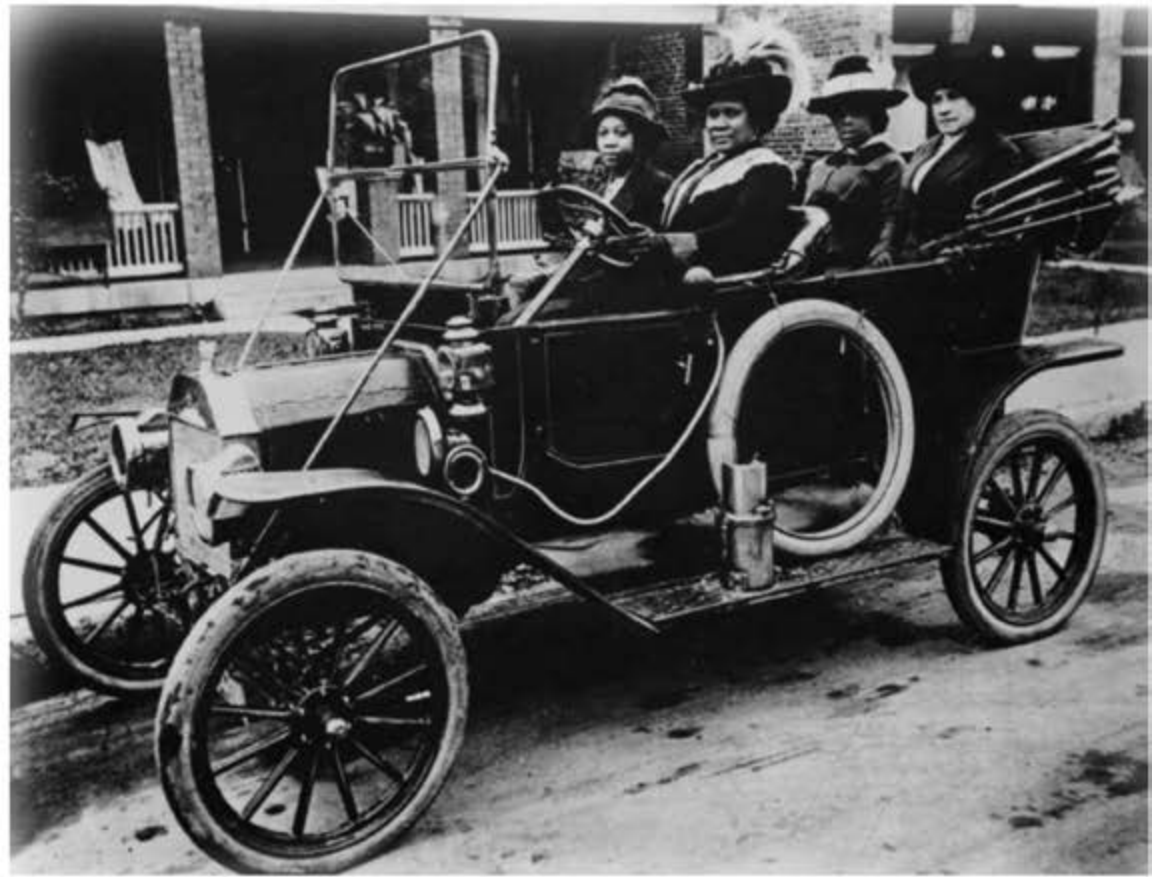

Fig. 1.

Fig. 2.

INVENTOR
Marjorie S. Joyner.
BY
E. C. Johnson
HER ATTORNEY





Más allá de Juneteenth: de 1865 al presente 6A-1

1,325,905.

A. H. PARKER.
HEATING FURNACE.
APPLICATION FILED JULY 9, 1918.

Patented Dec. 23, 1919.
2 SHEETS—SHEET 1.

Fig. 1.

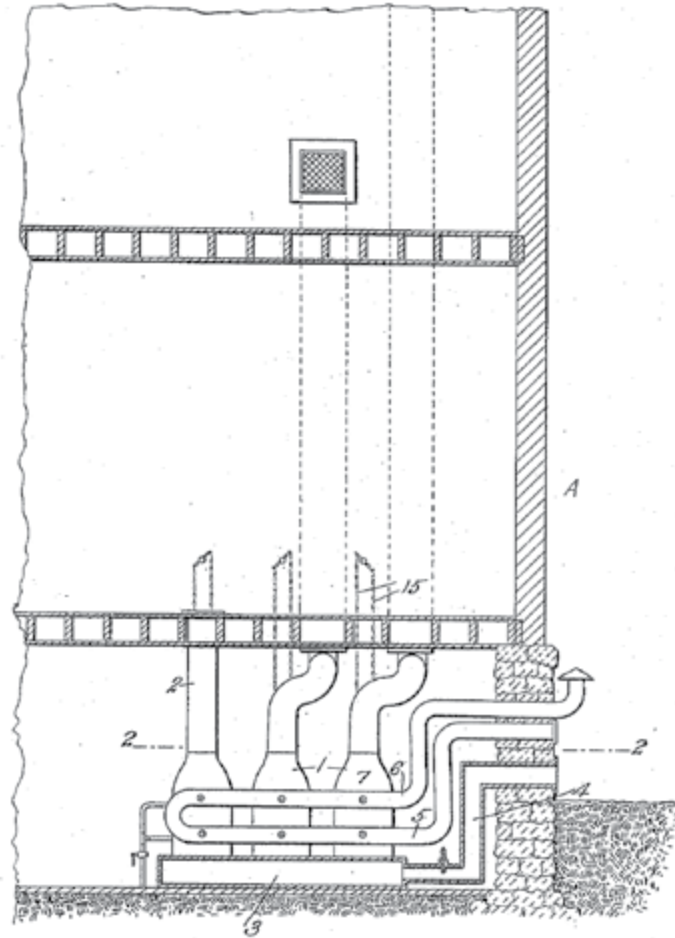
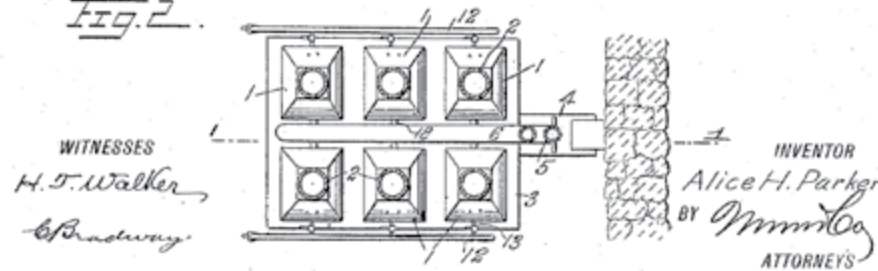
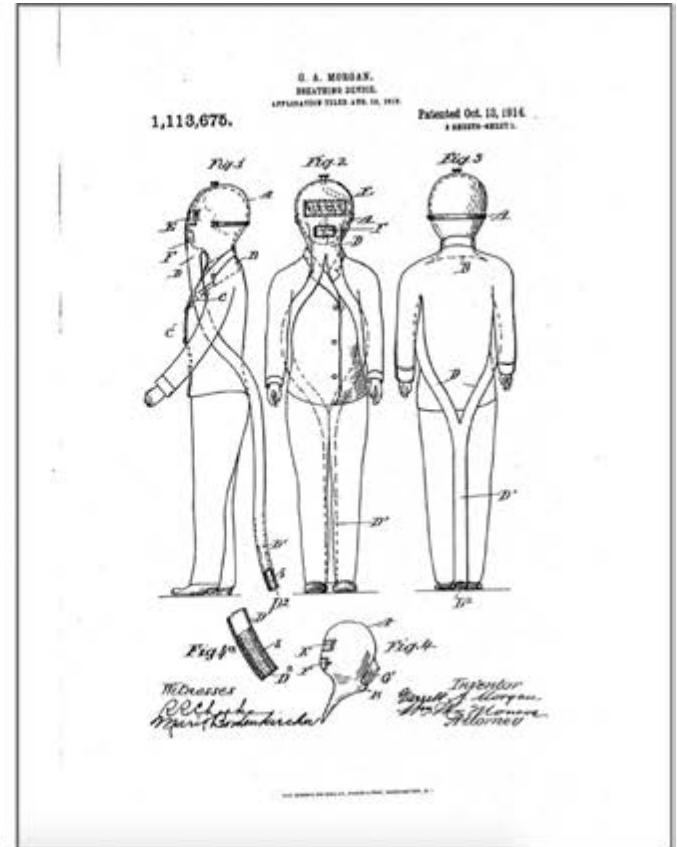
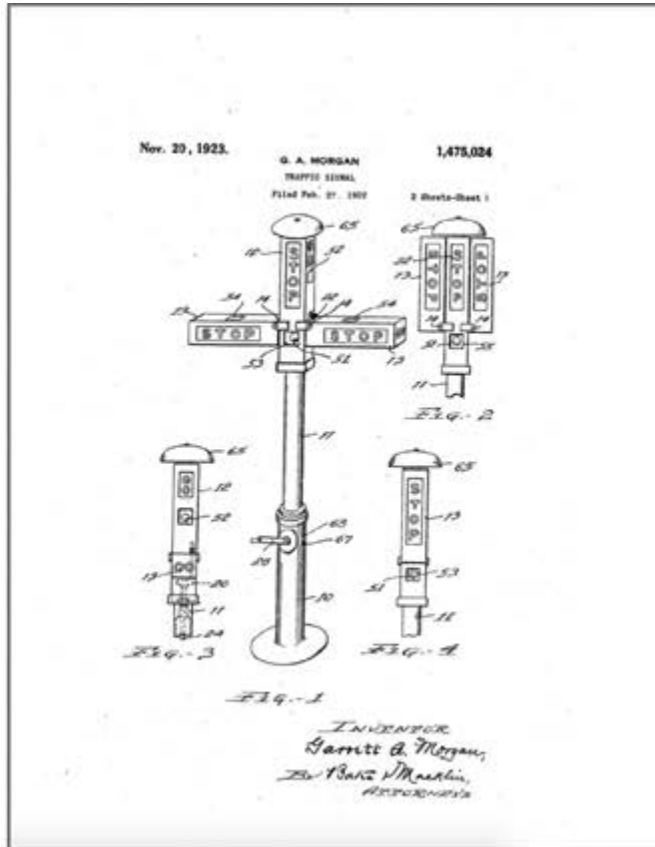

Fig. 2.





Más allá de Juneteenth: de 1865 al presente 6A-2





Más allá de Juneteenth: de 1865 al presente 6A-3

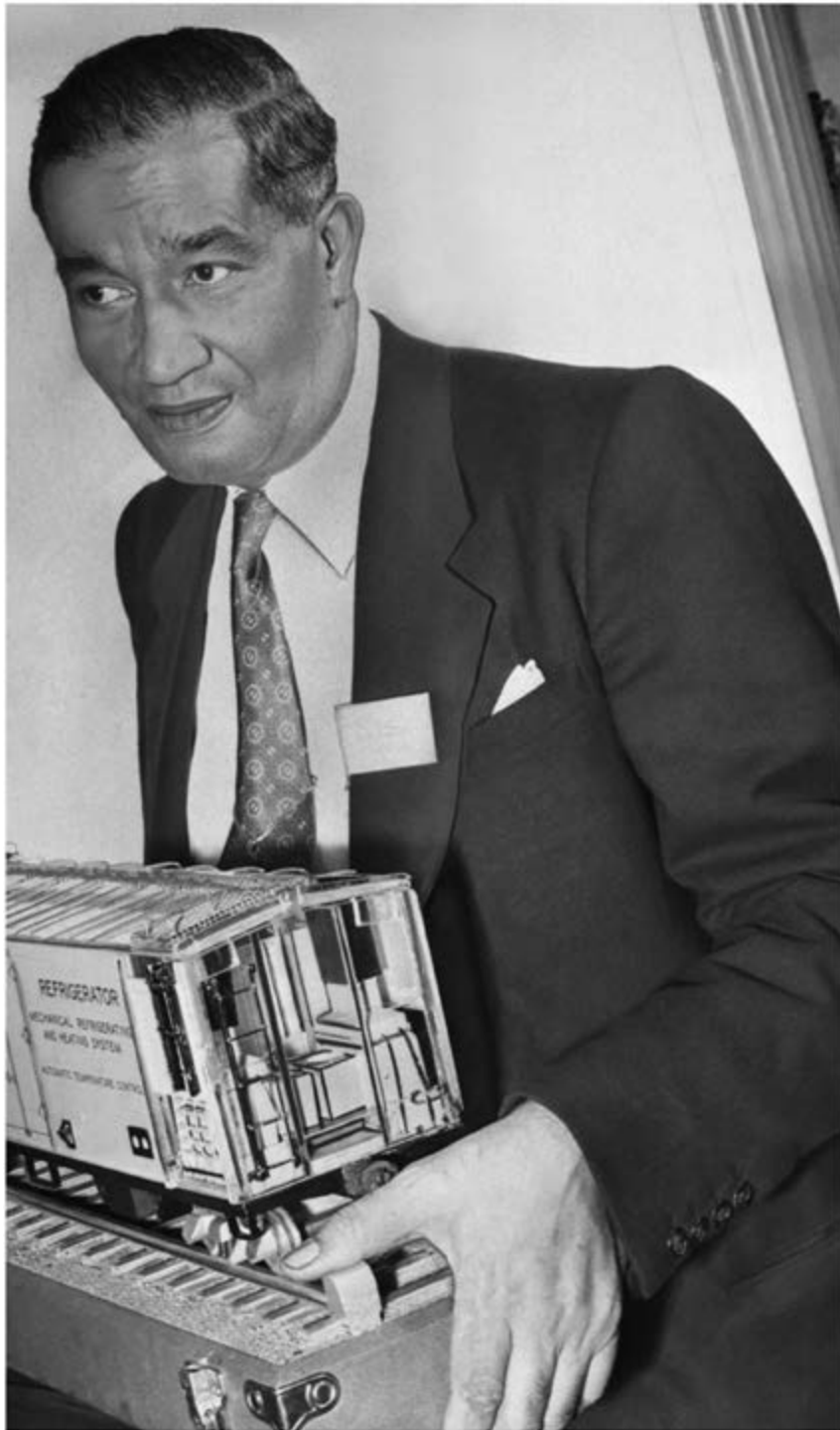

May 23, 1950

F. M. JONES
SYSTEM FOR CONTROLLING THE OPERATION
OF REFRIGERATION UNITS

2,509,099

Filed June 30, 1947

3 Sheets-Sheet 1

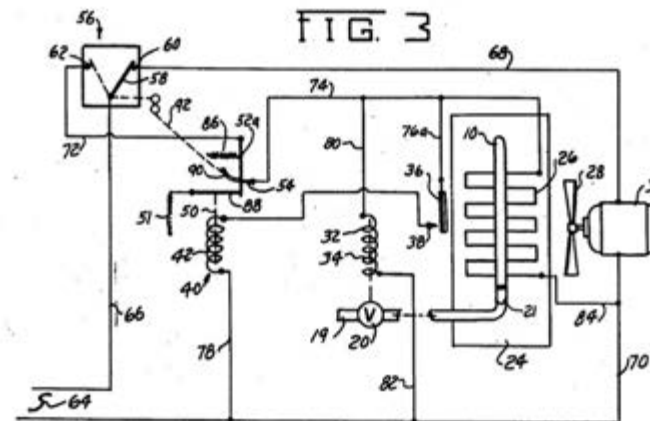
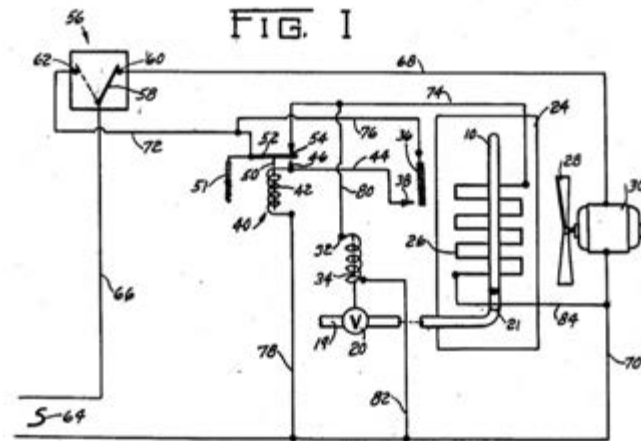

INVENTOR
FREDRICK M. JONES
BY *A. Q. Whiteley*
ATTORNEY



Más allá de Juneteenth: de 1865 al presente 6A-4

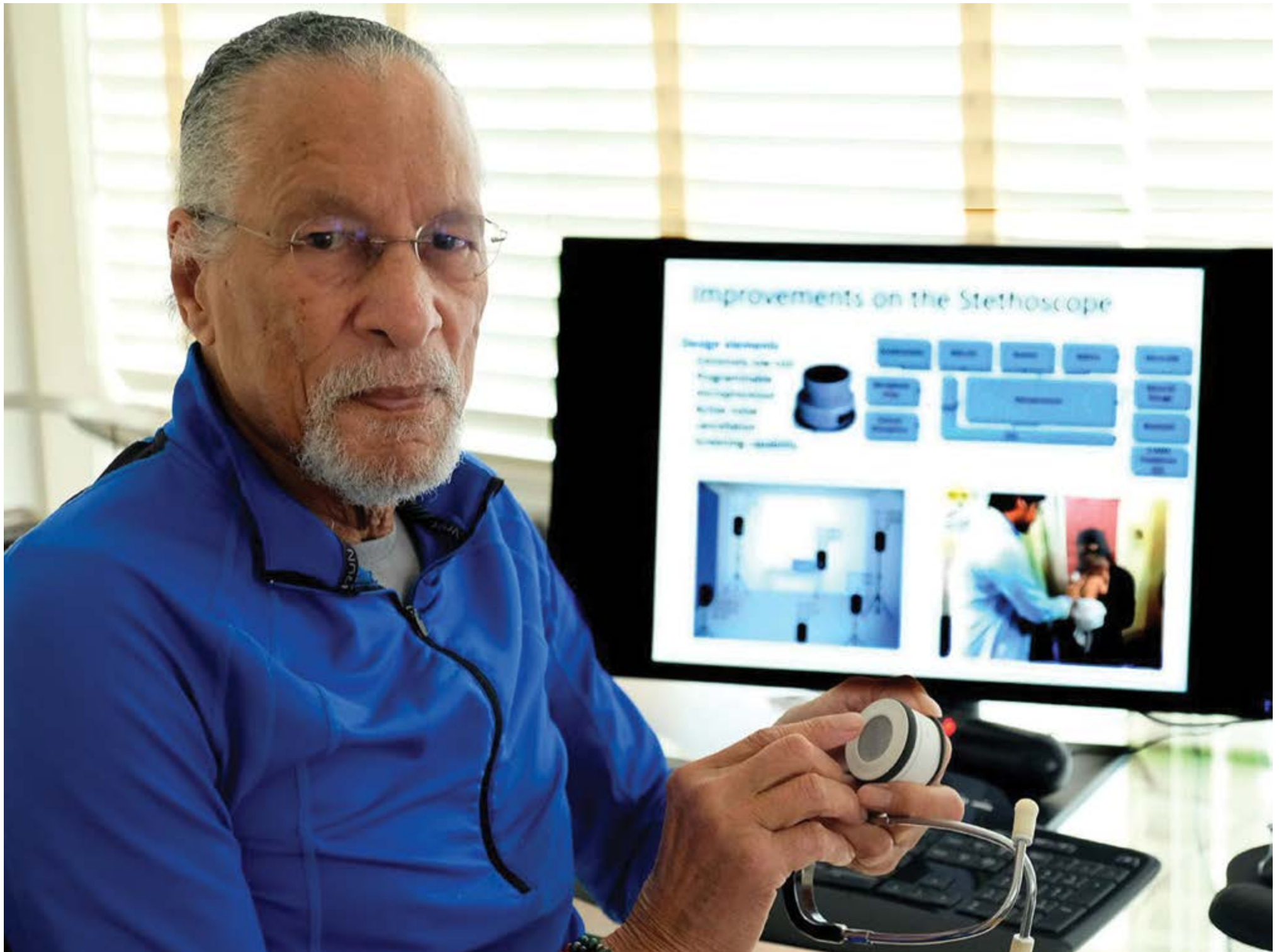

Improvements on the Stethoscope

Design Elements

- Compact size
- Programmable
- Intuitive
- Active noise cancellation
- Lightweight





Más allá de Juneteenth: de 1865 al presente 6A-5

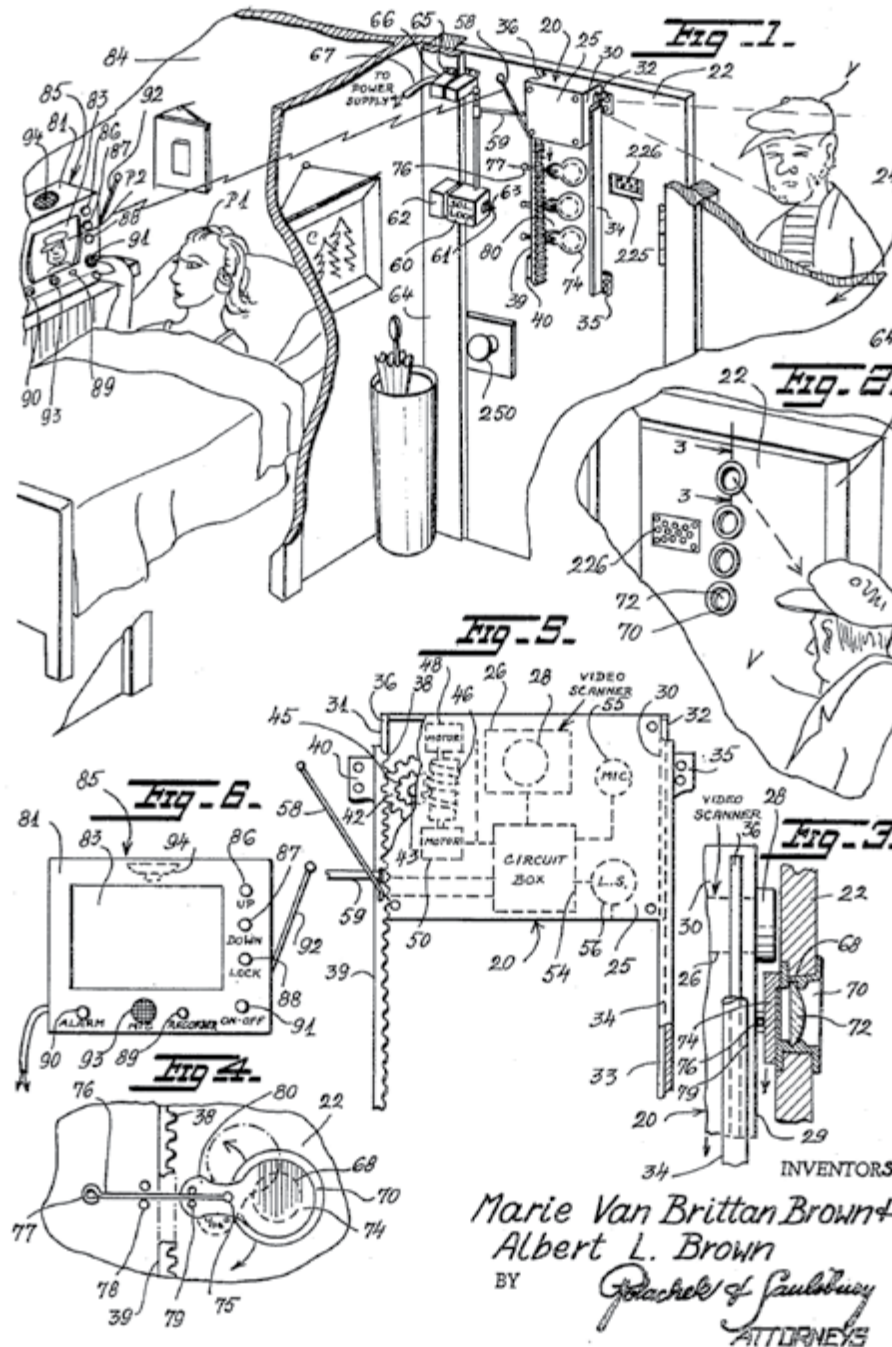



Más allá de Juneteenth: de 1865 al presente 6A-6



Más allá de Juneteenth: de 1865 al presente 6A-7



Más allá de Juneteenth: de 1865 al presente 6A-8





Más allá de Juneteenth: de 1865 al presente 9A-1





Más allá de Juneteenth: de 1865 al presente 9A-2





Más allá de Juneteenth: de 1865 al presente 9A-3





Más allá de Juneteenth: de 1865 al presente 9A-4

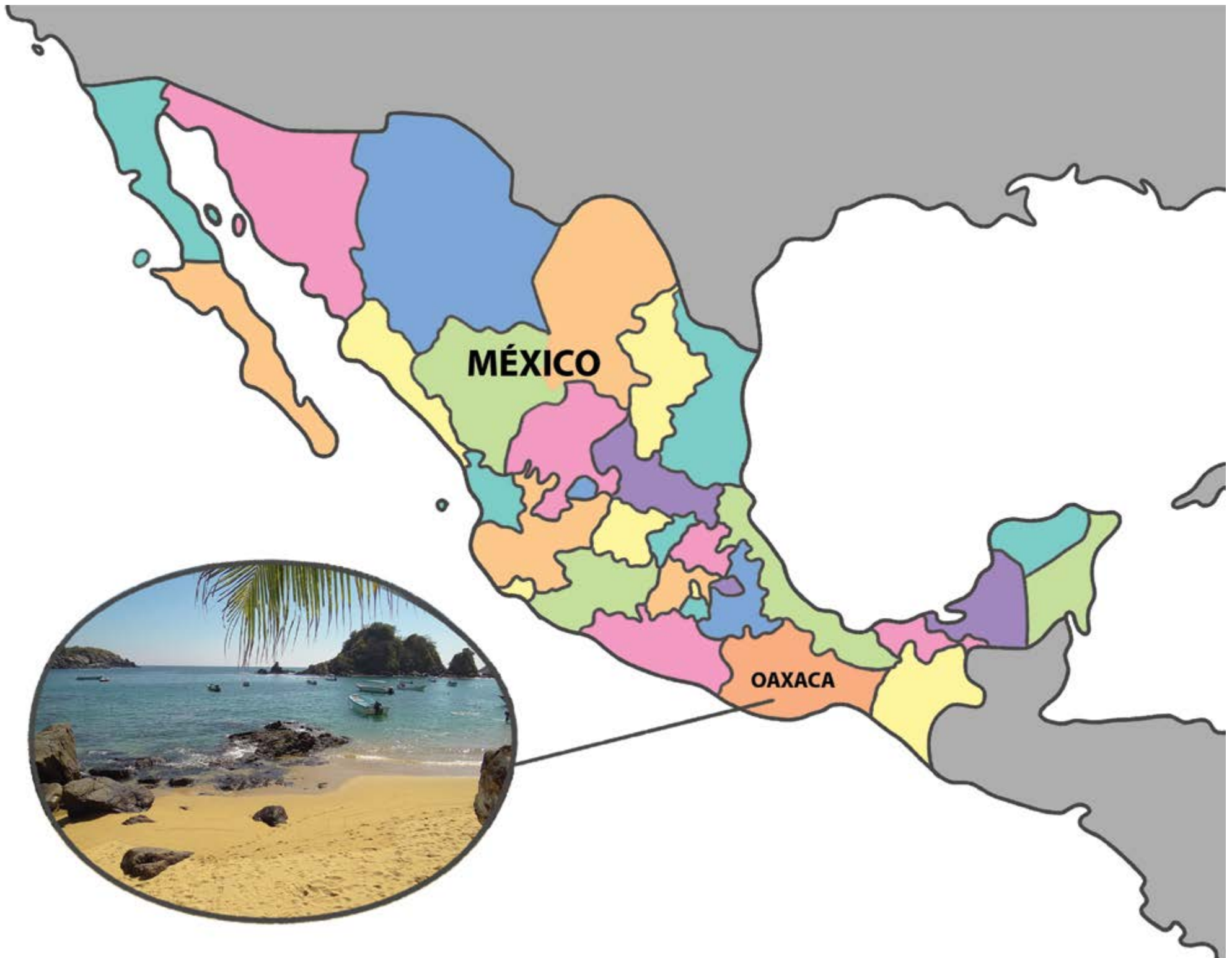



Más allá de Juneteenth: de 1865 al presente 9A-5

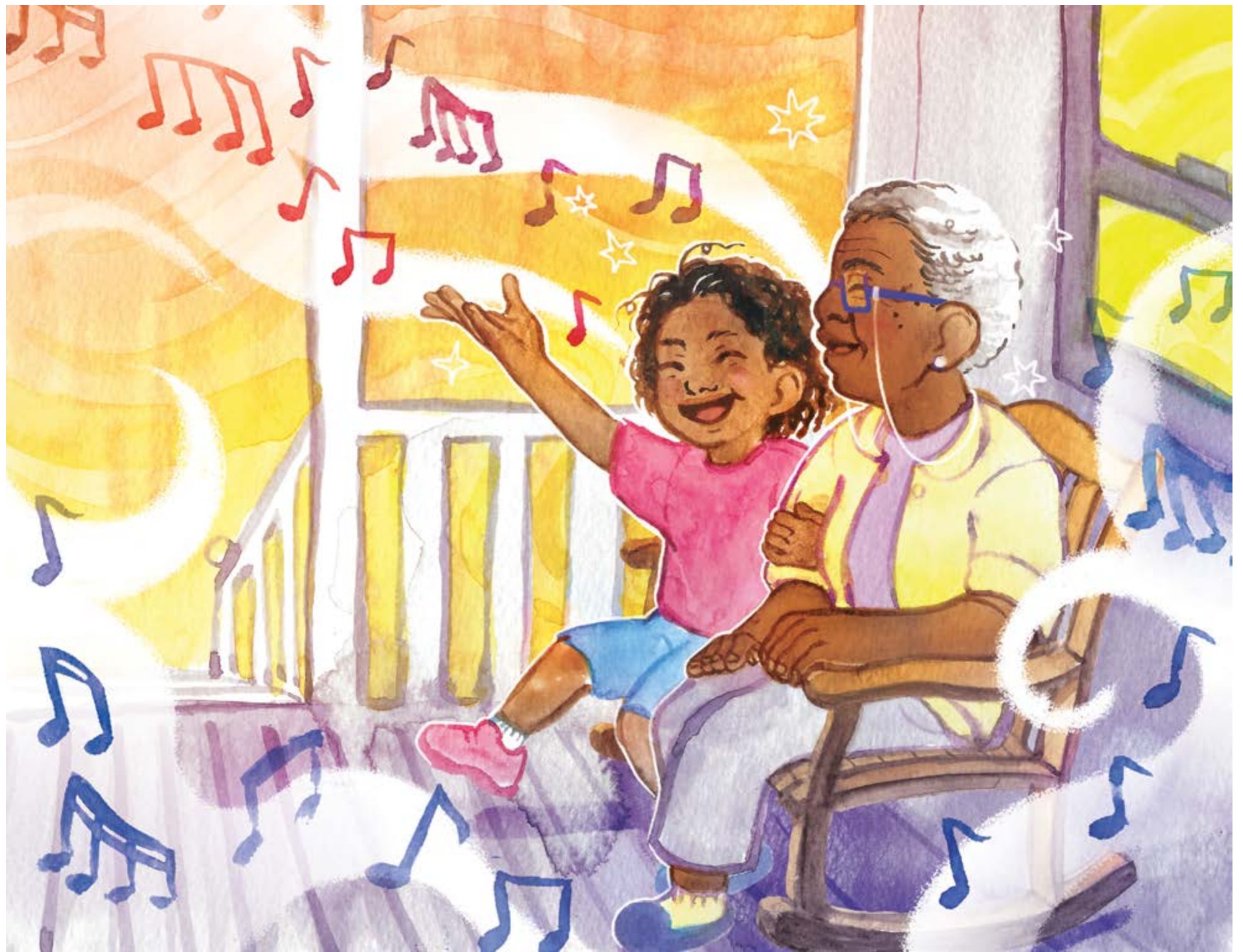



Más allá de Juneteenth: de 1865 al presente 9A-6

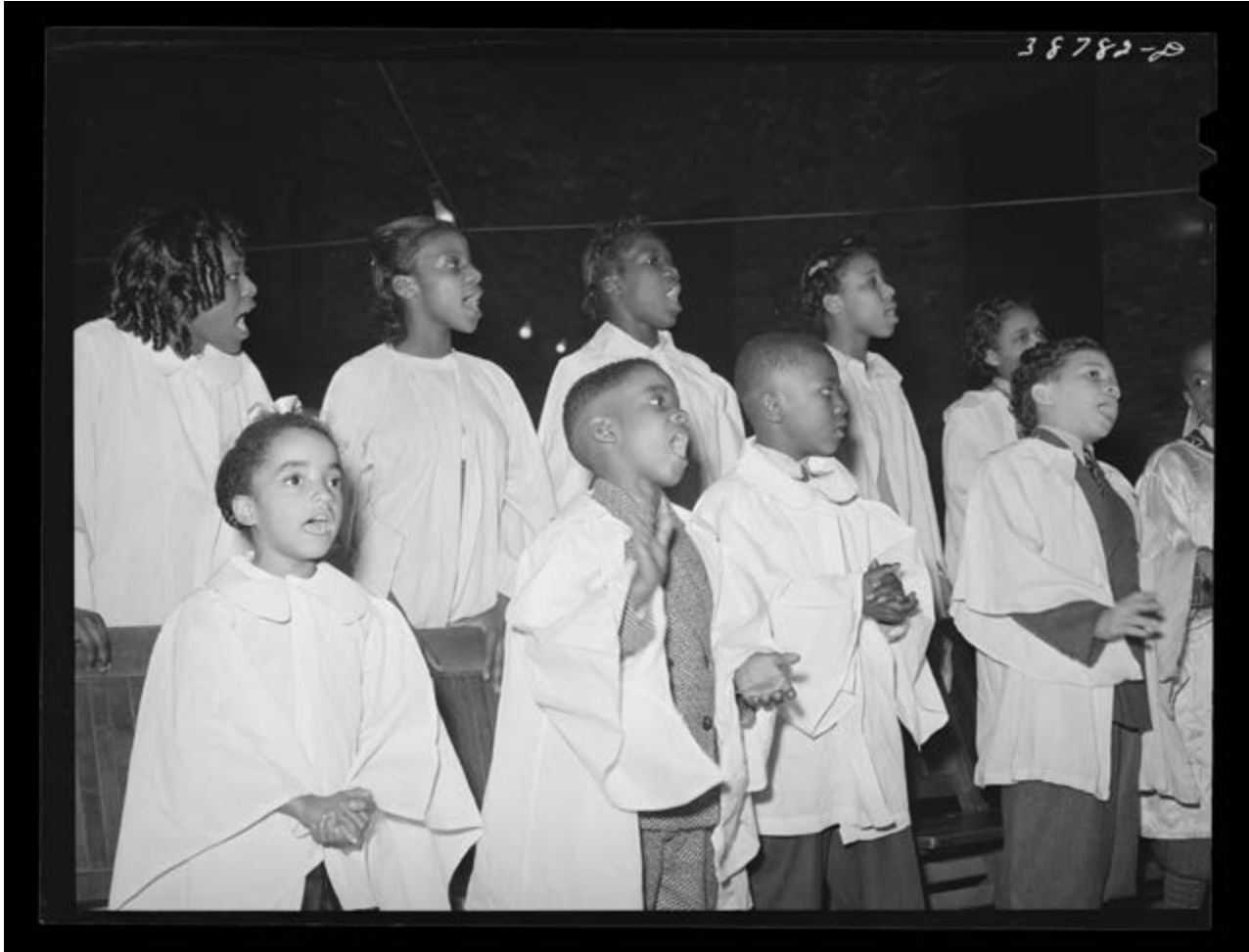



Más allá de Juneteenth: de 1865 al presente 9A-7





Más allá de Juneteenth: de 1865 al presente 9A-8





Más allá de Juneteenth: de 1865 al presente 9A-9

Core Knowledge Language Arts

Amplify.

General Manager K-8 Humanities and SVP, Product

Alexandra Clarke

Vice President, Elementary Literacy Instruction

Susan Lambert

Content and Editorial

Elizabeth Wade, PhD, Executive Director, Elementary Language Arts Content

Patricia Erno, Associate Director, Elementary ELA Instruction

Maria Oralia Martinez, Associate Director, Spanish Language Arts

Baria Jennings, EdD, Senior Content Developer

Sean McBride, Content and Instructional Specialist

Christina Cox, Managing Editor

Product and Project Management

Ayala Falk, Director, Business and Product Strategy, K-8 Language Arts

Amber McWilliams, Senior Product Manager

Elisabeth Hartman, Associate Product Manager

Catherine Alexander, Senior Project Manager, Spanish Language Arts

LaShon Ormond, SVP, Strategic Initiatives

Leslie Johnson, Associate Director, K-8 Language Arts

Thea Aguiar, Director of Strategic Projects, K-5 Language Arts

Zara Chaudhury, Project Manager, K-8 Language Arts

Design and Production

Tory Novikova, Senior Product Design Director

Erin O'Donnell, Senior Product Design Manager

Contributors

Content and Editorial

Sarah Cloos

Laia Cortes

Jayana Desai

Angela Donnelly

Claire Dorfman

Ana Mercedes Falcón

Rebecca Figueroa

Rachel Fisher

Nick García

Sandra de Gennaro

Patricia Infanzón-Rodríguez

Seamus Kirst

Michelle Korál

Jorge Limon

Jacqueline Ovalle

Raj Parameswaran

Soffia Pereson

Lilia Perez

Sheri Pineault

Megan Reasor

Marisol Rodriguez

Jessica Roodvoets

Lyna Ward

Product and Project Management

Stephanie Koleda

Zoe Seibel

Tamara Morris

Art, Design, and Production

Nanyamka Anderson

Raghav Arumugan

Dani Aviles

Olioli Buika

Sherry Choi

Stuart Dalgo

Edel Ferri

Pedro Ferreira

Nicole Galuszka

Parker-Nia Gordon

Isabel Hetrick

Ian Horst

Ashna Kapadia

Jagriti Khirwar

Julie Kim

Susan Licalsi

Lisa McGarry

Emily Mendoza

Marguerite Oerlemans

Lucas De Oliveira

Tara Pajouhesh

Jackie Pierson

Dominique Ramsey

Darby Raymond-Overstreet

Max Reinhardsen

Mia Saine

Nicole Stahl

Flore Thevoux

Jeanne Thornton

Amy Xu

Jules Zuckerberg

Other Contributors

Patricia Beam, Bill Cheng, Ken Harney, Molly Hensley, David Herubin, Sara Hunt, Kristen Kirchner, James Mendez-Hodes, Christopher Miller, Diana Projansky, Todd Rawson, Jennifer Skelley, Julia Sverchuk, Elizabeth Thiers, Amanda Tolentino, Paige Womack

Core Knowledge Language Arts

Core Knowledge Foundation

Series Editor-in-Chief

E. D. Hirsch, Jr.

President

Linda Bevilacqua

Editorial Staff

Mick Anderson
Robin Blackshire
Laura Drummond
Emma Earnst
Lucinda Ewing
Sara Hunt
Rosie McCormick
Cynthia Peng
Liz Pettit
Tonya Ronayne
Deborah Samley
Kate Stephenson
Elizabeth Wafler
James Walsh
Sarah Zelinke

Acknowledgments

These materials are the result of the work, advice, and encouragement of numerous individuals over many years. Some of those singled out here already know the depth of our gratitude; others may be surprised to find themselves thanked publicly for help they gave quietly and generously for the sake of the enterprise alone. To helpers named and unnamed we are deeply grateful.

Contributors to Earlier Versions of these Materials

Susan B. Albaugh, Kazuko Ashizawa, Kim Berrall, Ang Blanchette, Nancy Braier, Maggie Buchanan, Paula Coyner, Kathryn M. Cummings, Michelle De Groot, Michael Donegan, Diana Espinal, Mary E. Forbes, Michael L. Ford, Sue Fulton, Carolyn Gosse, Dorrit Green, Liza Greene, Ted Hirsch, Danielle Knecht, James K. Lee, Matt Leech, Diane Henry Leipzig, Robin Luecke, Martha G. Mack, Liana Mahoney, Isabel McLean, Steve Morrison, Juliane K. Munson, Elizabeth B. Rasmussen, Ellen Sadler, Rachael L. Shaw, Sivan B. Sherman, Diane Auger Smith, Laura Tortorelli, Khara Turnbull, Miriam E. Vidaver, Michelle L. Warner, Catherine S. Whittington, Jeannette A. Williams

We would like to extend special recognition to Program Directors Matthew Davis and Souzanne Wright who were instrumental to the early development of this program.

Schools

We are truly grateful to the teachers, students, and administrators of the following schools for their willingness to field test these materials and for their invaluable advice: Capitol View Elementary, Challenge Foundation Academy (IN), Community Academy Public Charter School, Lake Lure Classical Academy, Lepanto Elementary School, New Holland Core Knowledge Academy, Paramount School of Excellence, Pioneer Challenge Foundation Academy, New York City PS 26R (The Carteret School), PS 30X (Wilton School), PS 50X (Clara Barton School), PS 96Q, PS 102X (Joseph O. Loretan), PS 104Q (The Bays Water), PS 214K (Michael Friedsam), PS 223Q (Lyndon B. Johnson School), PS 308K (Clara Cardwell), PS 333Q (Goldie Maple Academy), Sequoyah Elementary School, South Shore Charter Public School, Spartanburg Charter School, Steed Elementary School, Thomas Jefferson Classical Academy, Three Oaks Elementary, West Manor Elementary.

And a special thanks to the Pilot Coordinators Anita Henderson, Yasmin Lugo-Hernandez, and Susan Smith, whose suggestions and day-to-day support to teachers using these materials in their classrooms was critical.

Design and Graphics Staff

Kelsie Harman
Liz Loewenstein
Bridget Moriarty
Lauren Pack

Consulting Project Management Services

ScribeConcepts.com

Additional Consulting Services

Erin Kist
Carolyn Pinkerton
Scott Ritchie
Kelina Summers



Credits

Every effort has been taken to trace and acknowledge copyrights. The editors tender their apologies for any accidental infringement where copyright has proved untraceable. They would be pleased to insert the appropriate acknowledgment in any subsequent edition of this publication. Trademarks and trade names are shown in this publication for illustrative purposes only and are the property of their respective owners. The references to trademarks and trade names given herein do not affect their validity.

All photographs are used under license from Shutterstock, Inc. unless otherwise noted.

Illustration and Image Sources

Cover: Everett Collection/Shutterstock.com; 1A-1: Stephenson, Mrs. Charles (Grace Murray). [Emancipation Day Celebration, June 19, 1900], photograph, June 19, 1900; (<https://texashistory.unt.edu/ark:/67531/metaph124053/m1/1/>: accessed March 8, 2021), University of North Texas Libraries, The Portal to Texas History, <https://texashistory.unt.edu>; crediting Austin History Center, Austin Public Library. Public Domain via Wikimedia Commons; 1A-2: (left) "General Order No. 3" from the holdings of the US National Archives and Records Administration/ RG 393, Part II, Entry 5543, District of Texas, General Orders Issued/Public Domain via Wikimedia Commons, (right) Library of Congress, Prints & Photographs Division [LC-DIG-pga-04067]; 1A-3: Everett Collection/Shutterstock.com; 1A-4: (left) "Madam C.J. Walker in an early automobile." Public Domain via Wikimedia Commons; (right) Collection of the Smithsonian National Museum of African American History and Culture, Gift from Dawn Simon Spears and Alvin Spears, Sr.; 1A-5: Schomburg Center for Research in Black Culture, Photographs and Prints Division, The New York Public Library. "Portrait of Arthur Alfonso Schomburg, bibliophile" The New York Public Library Digital Collections. 1900 - 1935. <https://digitalcollections.nypl.org/items/8ed2b31e-6166-281c-e040-e00a18061fde>; 1A-6: (top) Trikosko, Marion S/ Library of Congress, Prints & Photographs Division [LC-U9-14459- 5A], (bottom left) Library of Congress, Prints & Photographs Division [LC-USZ62-16767], (bottom right) Library of Congress, Prints & Photographs Division, Visual Materials from the Rosa Parks Papers, [LC-DIG-ppmsca-47017]; 1A-7: Leffler, Warren K./ Library of Congress, Prints & Photographs Division [LC-U9- 27228-9]; 1A-8: (Obama, top left) Evan El-Amin/Shutterstock.com, (Jordon, top right) Leffler, Warren K./Library of Congress, Prints & Photographs Division [LC-U9-32937-32A/33]; (Chavez, bottom left) Trikosko, Marion S./Library of Congress, Prints & Photographs Division [LC-U9-37548- 29/29A], (Obama/Huerta, bottom right) Rena Schild/Shutterstock.com; 1A-9: Orna Wachman/Pixabay 5A-1: Source: United States Patent and Trademark Office, www.uspto.gov; 5A-2: Public Domain via Wikimedia Commons; 5A-3: (left) "Elijah McCoy" by Ypsilanti Historical Society, courtesy of Wikimedia Commons, is licensed under CC BY-SA 4.0 <https://creativecommons.org/licenses/by-sa/4.0/deed.en>, (right) Source: United States Patent and Trademark Office, www.uspto.gov; 5A-4: (left) Public Domain via Wikimedia Commons, (right) Source: United States Patent and Trademark Office, www.uspto.gov; 5A-5: (left) Public Domain via Wikimedia Commons, (right) Source: United States Patent and Trademark Office, www.uspto.gov; 5A-6: Source: United States Patent and Trademark Office, www.uspto.gov; 5A-7: Source: United States Patent and Trademark Office, www.uspto.gov; 6A-1: (left) Source: United States Patent and Trademark Office, www.uspto.gov, (right) "Madam C.J. Walker in an early automobile." Public Domain via Wikimedia Commons; 6A-2: Source: United States Patent and Trademark Office, www.uspto.gov; 6A-3: (left) Fotosearch/Getty Images, (center and right): Source: United States Patent and Trademark Office, www.uspto.gov; 6A-4: (left) Bettmann/Getty Images, (right) Source: United States Patent and Trademark Office, www.uspto.gov; 6A-5: "Dr. James Edward Maceo West" by Sonavi Labs, courtesy of Wikimedia Commons, is licensed under CC BY-SA 4.0 <https://creativecommons.org/licenses/by-sa/4.0/deed.en>; 6A-6: Source: United States Patent and Trademark Office, www.uspto.gov; 6A-7: (left) Chris Ware/Bloomberg/Getty Images, (center and right) Source: United States Patent and Trademark Office, www.uspto.gov; 6A-8: (left) Jemal Countess/Getty Images, (center and right) Source: United States Patent and Trademark Office, www.uspto.gov; 9A-1: Olioli Buika; 9A-2: Olioli Buika; 9A-3: fldcc/Shutterstock.com; 9A-4: Olioli Buika; 9A-5: (map) Jackie Pierson, (beach) "Beach Scene" by Adam Jones, courtesy of Wikimedia Commons, is licensed under CC BY-SA 2.0 <https://creativecommons.org/licenses/by-sa/2.0/deed.en>; 9A-6: Olioli Buika; 9A-7: (left) Lee, Russell. Library of Congress N.Y. Prints & Photographs Division, Farm Security Administration/Office of War Information Black-and-White Negatives [LC-USF34- 038782-D], (right) Library of Congress N.Y. Prints & Photographs Division [LC-USZ62-42992]; 9A-8: Olioli Buika; 9A-9: Olioli Buika.

Regarding the Shutterstock items listed above, please note: "No person or entity shall falsely represent, expressly or by way of reasonable implication, that the content herein was created by that person or entity, or any person other than the copyright holder(s) of that content."

